

Operation Manual

Transmitter EC22

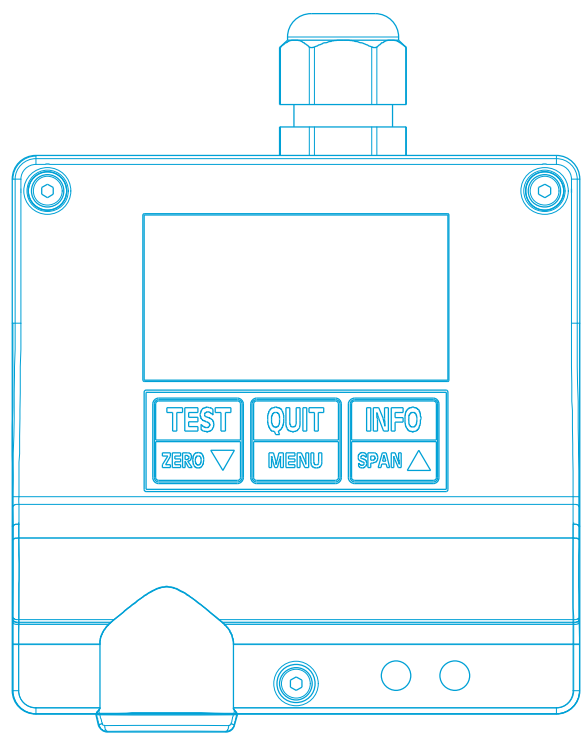
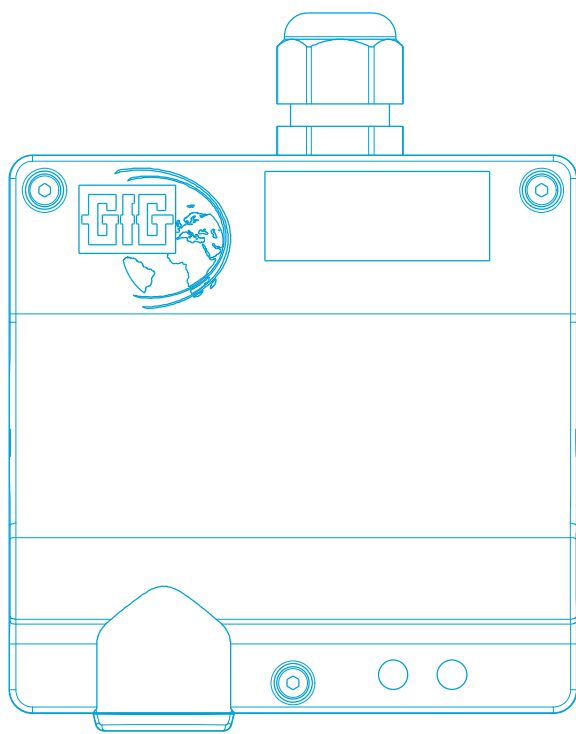

Translation of the original operation manual

Table of Contents

	Page
1 INTRODUCTION	4
1.1 For Your Safety	4
1.2 Operating notes	4
2 GENERAL INFORMATION ABOUT THE TRANSMITTER	5
2.1 General description	5
2.2 Measurement method	5
2.3 Transmission behavior	5
2.4 Device overview	6
3 MOUNTING AND INSTALLATION INSTRUCTIONS	7
3.1 Mounting location	7
3.2 Mounting	7
3.3 Install electrical connections	7
4 OPERATING NOTES	8
4.1 Commissioning	8
4.2 Measuring mode	9
4.2.1 Overrange	10
4.2.2 Underrange	10
4.2.3 Push button interface	10
4.2.4 Display, LED and horn test [TEST]	11
4.2.5 Display of Operating Parameters [INFO]	11
4.2.6 Sensor life	11
4.3 Calibration and Adjustment	11
4.3.1 Zero point calibration	11
4.3.2 Zero adjustment with display and push button interface [ZERO]	12
4.3.3 Zero point adjustment with the AutoCal button [ZERO]	12
4.3.4 Zero point adjustment with the ZERO potentiometer	12
4.3.5 Sensitivity calibration	13
4.3.6 SPAN adjustment with display and push button interface [SPAN]	13
4.3.7 Sensitivity adjustment with the AutoCal button [SPAN]	13
4.3.8 Sensitivity adjustment with the SPAN potentiometer	14
4.3.9 Remote calibration and adjustment	15
4.4 Main and Service Menu [MENU]	16
4.4.1 Main Menu	16
4.4.2 Service-Menu	17
4.5 Readouts and Messages	19
4.5.1 Overview of status LED states and current output signals	19
4.5.2 Displaying special states (device start and fault)	19
4.5.3 Readouts in service mode and during sensor adjustment	20
4.5.4 Readouts in measuring mode	21
4.5.5 Priority of readouts and messages in measuring mode	22
4.6 Fault, cause, remedy	22

5	APPENDIX	23
5.1	Cleaning and Care	23
5.2	Service and Maintenance	23
5.2.1	Visual inspection	23
5.2.2	Function check	23
5.2.3	System check (Proof Test)	23
5.2.4	Repair	23
5.3	Replacing the sensor	23
5.4	Note on the environmentally friendly disposal of used parts	24
5.5	Accessories and spare parts	24
5.6	Sensor specification	24
5.7	Technical Data	28
5.8	Declarations of Conformity	29
5.9	Housing drawing and mounting template EC22	32
5.10	Housing drawing and mounting template EC22 O	33

1 INTRODUCTION

1.1 For Your Safety

In accordance with the act on making products available on the market (Product Safety Act - ProdSG), these operating instructions refer to the intended use of the product and serve to protect the safety and health of persons and the safety of plants. It must be read and observed by all persons who use, maintain, service and control this product. This device can only fulfill its intended purpose if it is used, maintained, serviced and controlled according to the instructions of GfG Gesellschaft für Gerätebau mbH.

The warranty given by GfG expires if it is not used, maintained, serviced and checked in accordance with the instructions of GfG. The foregoing does not alter the information on warranty and liability in GfG's Terms and Conditions of Sale and Delivery.

1.2 Operating notes

In accordance with national regulations, gas warning devices must be tested for function by a competent person after installation but before measurement operation is started (initial commissioning). In Germany, "DGUV Information 213-056 (Leaflet T 021 / previously BGI 836 Section 8.1)" and "DGUV Information 213-057 (Leaflet T 023 / previously BGI 518 Section 8.1)" apply to this.

The transmitter has been tested for function and correct display of the measured values before delivery. Calibration and adjustment were performed using appropriate test or calibration gases.

This does not release you from calibration and, if necessary, adjustment after installation.

The transmitter EC22 is **not** approved for use in hazardous areas.



CAUTION:

**The supply voltage must not exceed 30 V DC!
This also applies to voltage peaks!**

2 GENERAL INFORMATION ABOUT THE TRANSMITTER

2.1 General description

A fixed gas detection system consists of a transmitter and a controller (GMA - gas measuring and evaluation unit, not included in the scope of delivery). Transmitter and GMA are connected via a cable. The transmitter converts the gas concentration into an electrical measurement signal and sends it for further processing to the controller.

The transmitter EC22 can optionally be equipped with an additional graphic display with operating keys and acoustic signaling device. In measurement mode, the backlight of the display is green. In the event of a fault or alarm, the backlight color changes to red for visual alarm. The display variant also features a horn for acoustic alerting.

Each transmitter of the 22 series has two status LEDs to indicate the operating status. A green one to signal operational readiness and a yellow one to indicate a fault or special condition.

The transmitters of the 22 series can optionally be equipped with an analog current interface or a digital RS-485 interface. The current interface outputs the measurement information with 4-20 mA as standard or alternatively with 0.2-1 mA. The communication of the digital RS-485 interface takes place according to the Modbus (RTU) protocol.

The electronics take over a multitude of tasks which, on the one hand, facilitate operation and maintenance and, on the other hand, considerably increase operational reliability and measuring accuracy. The transmitter is characterized by:

- Display of the measured gas concentration (version with display)
- Settings via push buttons without having to open the housing (version with display)
- Compensation of temperature influences
- Continuous display of the status (measuring operation, fault or special status) on the transmitter

2.2 Measurement method

The sensors installed in the EC22 transmitter are electrochemical sensors. Electrochemical Sensors contain an electrolyte, a working electrode (anode), a counter electrode (cathode) and, if necessary, a reference electrode. Matching to the type of gas to be monitored is achieved by specific electrodes in combination with a suitable electrolyte. With this measuring method, an electrical signal proportional to the gas concentration is generated in the measuring cell. This electrical signal is converted by the electronics integrated in the EC22 into a standardized analog current signal (4-20 mA or 0.2-1 mA) or into a digital bus signal.

2.3 Transmission behavior

Depending on the type of measuring gas, the transmitter has different transmission characteristics. The adjustment times may vary depending on the gas to be measured. The displayed gas concentration and the output signal are always proportional to the gas concentration.

2.4 Device overview

EC22 without display

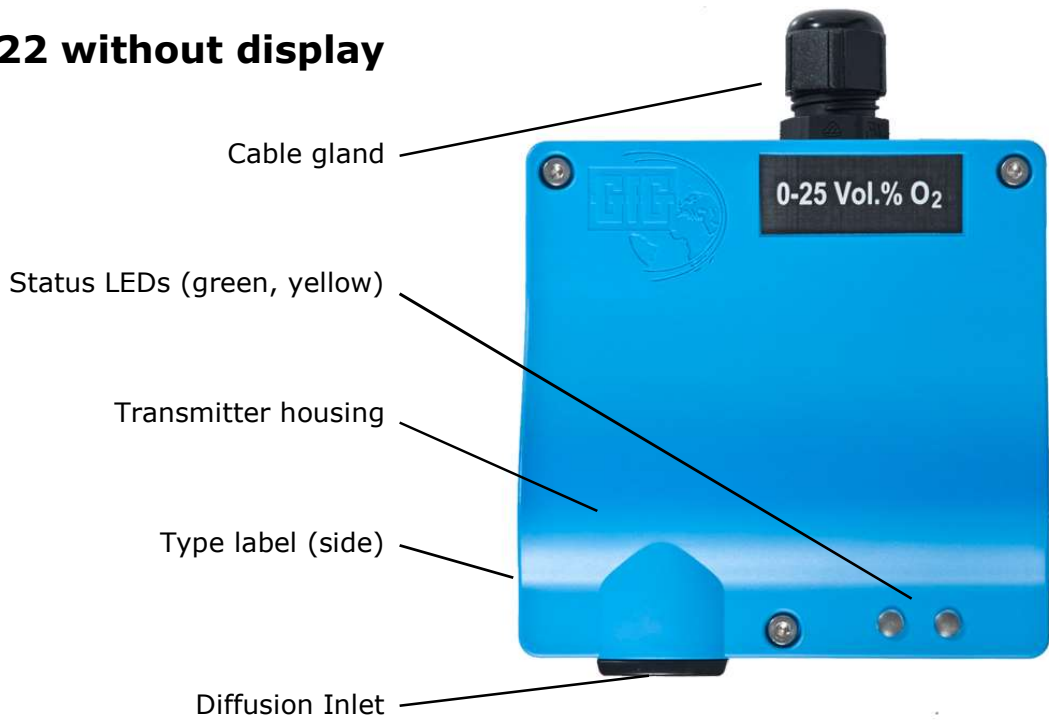

EC22 with display



The transmitter housing contains the gas sensor and the transmitter electronics. The electronics converts the measuring signal into a gas concentration which is then signaled via an analog current signal of 4-20 mA or 0.2-1 mA or a digital RS-485 bus signal using the Modbus RTU protocol. In the display variant, gas concentration and status information are displayed.

The adjustment of the transmitter can be done using a multimeter and the two built-in potentiometers or - if available - via the display and the push buttons.

3 MOUNTING AND INSTALLATION INSTRUCTIONS

3.1 Mounting location

When determining the mounting location, it is important to know the environmental conditions precisely and to take them into account when selecting the location. In order to obtain representative measurement results, the ventilation conditions must be taken into account.

The transmitter must be installed in the room in such a way that the gases reach the sensor even with unfavorable ventilation. If necessary, a test, e.g. with smoke generator vials, must be carried out.

When determining the mounting location, it must also be ensured that the transmitter is always freely accessible for service and calibration work.

Attention should also be paid to external influences such as:

- Rainwater, gushing water, dripping water, condensate
- the amount of dust in the ambient air

The transmitter is largely protected against ingress of water and dust. Under very difficult measuring conditions, special accessories can protect the transmitter from damage. Contact GfG for more information.



If the sensor is exposed to environmental conditions unknown to GfG at the time of planning or delivery, the warranty may be voided.

3.2 Mounting

When determining the mounting location, it must also be ensured that the transmitter is always freely accessible for service and calibration work. The mounting position of the transmitter must be vertical with the sensor pointing downwards.

The transmitter is connected to the controller according to the connection diagram (see *connections and terminal assignment*). For mounting, the three Allen screws must be loosened and the housing cover removed. The housing is fixed with three screws. Inside the housing is the printed circuit board. The connection terminals for the connection to the controller are located in the upper area of the printed circuit board.

3.3 Install electrical connections

The laying of the cables and the connection of the electrical installation may only be carried out by a specialist in compliance with the relevant regulations. The wire cross-section depends on the length of the connecting cable and the transmitter variant. It must be checked in each individual case whether the operating voltage of the bus version is sufficient to supply the last transmitters on the transmitter bus. If necessary, the power supply must be upgraded by an additional voltage source. After installation, the cover of the housing must be closed and screwed down again.

For analog data transmission, a cable with the wire cross-section of 0.34 mm² can be used for shorter distances up to 500 m. For longer distances, the wire cross-section should be 0.75 mm². The length of the cable should not exceed 1200 m.

Connection diagram:

Terminals for cable connection

- 1: Data- D0
- 2: Data+ D1 / 4-20 mA / 0,2-1 mA
- 3: 0 V GND
- 4: 24 V DC (12 to 30 V DC)

Slide switch (Rt)

Terminating resistor for RS-485
(Factory setting = OFF)

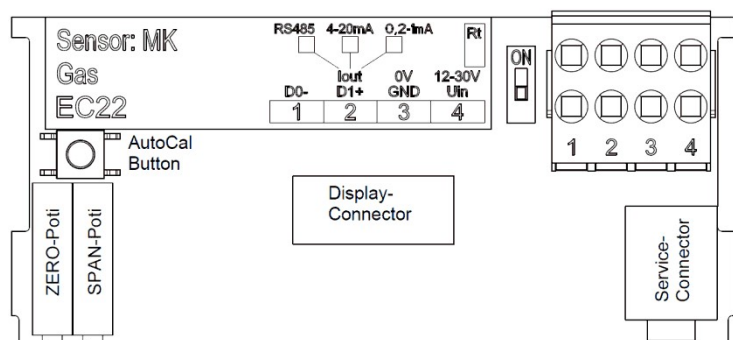

For digital data transmission via RS-485, the bus cabling depends on various factors. This includes the structure of the bus as a string or as a ring, the number of transmitters on the bus, the distance of the individual transmitters from the controller, the transmitter type/variant, the sensor type and, of course, the bus cable type. It must be checked in each individual case whether the operating voltage of the bus version is sufficient to supply the last transmitters on the transmitter bus. If necessary, the power supply must be upgraded by an additional voltage source. The length of the cable should not exceed 1200 m.

The following example shows the maximum cable lengths for the installation of 8x EC22 each at a distance of 10m at the end of the bus cable harness. EC22 refers to devices without display, EC22 D to devices with display, and EC22 DA to devices with display and alarm device.



Sensor	EC22	EC22 D	EC22 DA	Cable
all sensors	1200 m	1200 m	1200 m	2x2x1,5mm ²
	1200 m	1200 m	850 m	2x2x1,0mm ²
	1200 m	650 m	450 m	2x2x0,5mm ²

(2x2x0.5 mm² = 2x2x0.8 mm)

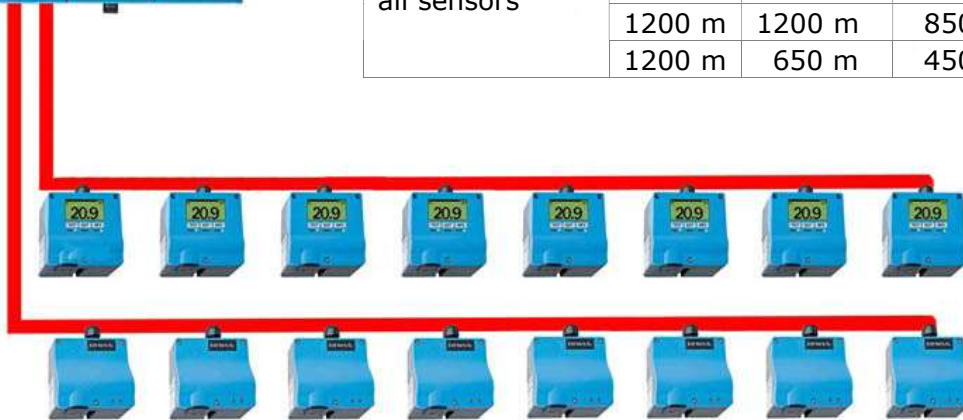

4 OPERATING NOTES

4.1 Commissioning

The EC22 transmitter has been tested for function and correct display of the measured values before delivery. The adjustment was performed using appropriate test or calibration gases. However, depending on transport, assembly and ambient conditions, deviations may arise. For this reason, the gas detection system must be commissioned and tested for function by a qualified person.

After power on, the transmitter sometimes needs a few minutes for:

- a self-test during which the program and RAM are checked.
- reading and evaluation of the device parameters including a simultaneous memory check
- reading and evaluation of the sensor parameters including a simultaneous memory check
- the stabilising of the sensor

During the startup phase, memory tests are performed within the first few seconds.

Version with analog current interface (0.2-1mA):

Immediately after power-on the current interface emits 0.0 mA and after 4 seconds 0.08 mA. The green and yellow LEDs are lit.

Version with analog current interface (4-20 mA):

Immediately after power-on the current interface emits 0.0 mA and after 4 seconds 1.6 mA. The green and yellow LEDs are lit.

Version with digital Modbus interface (RS-485):

With the Modbus version, "Startup" can be read on the connected controller, e.g. GMA200. If necessary, refer to the Modbus appendix to the transmitter series 22 operation manuals.

First, the information about the firmware versions appears in the display of the EC22. The measuring range, unit of measurement, gas type and calibration gas concentration are then displayed. The remaining seconds of the run-in phase are counted down in the display. The EC22 automatically switches to measuring mode after the sensor run-in phase.

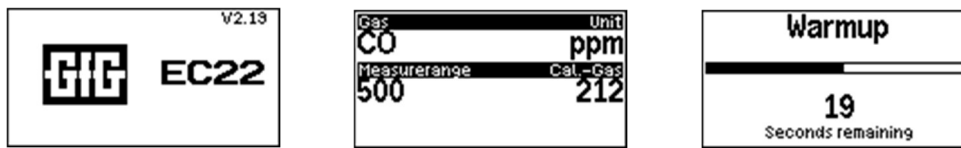

If a device error is detected during the startup phase, the device switches to fault operation.

Version with analog current interface (0.2-1mA):

The current interface then outputs 0.06 mA. An error message is shown in the display (see Indications of special states and malfunctions). The yellow fault LED lights up continuously.

Version with analog current interface (4-20 mA):

The current interface then outputs 1.2 mA. An error message is shown in the display (see Indications of special states and malfunctions). The yellow fault LED lights up continuously.

Vesion with digital Modbus interface (RS-485):

In the Modbus version, an error message is shown in the display of the transmitter and/or the GMA (see Indications of special states and malfunctions). The yellow fault LED lights up continuously.

Notice:

The initial commissioning of the transmitter requires a check and, if necessary, adjustment of the zero point (ZERO) and subsequently also of the sensitivity (SPAN) after the run-in period.

4.2 Measuring mode

In fault-free measuring mode, the green operation LED is permanently on and the yellow fault LED is off. The functionality of the electronics is constantly monitored by various tests, such as sensor, processor and memory tests. The measurement of the gas concentration is continuous and is updated every second.

The digital display shows the currently detected gas concentration in measuring mode.

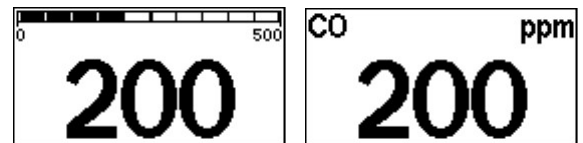

 In normal measuring mode display of the transmitter shows a bar graph with the set measuring range above the current gas concentration and also the gas type and the gas unit in 5-second intervals.

Up to three limit value alarms can be configured on the EC22 with display, signaling is acoustic and optical in the display with red background lighting. An alarm is triggered as soon as the gas concentration exceeds or falls below the set alarm limit value. Depending on the function setting, the alarm reset of the limit value alarms can be carried out automatically or, in the case of latching alarms, after the alarm value has fallen below (or has exceeded) the limit value, with acknowledgement by pressing the  button.



 **Caution: As soon as the remote calibration of measuring points has been started at the connected GMA, the alarm is suppressed for the duration of the remote calibration!**

4.2.1 Overrange

An overrange between 100 and 112 % of the measuring range is indicated in the display by arrows ↑↑↑ alternating with the measured value.

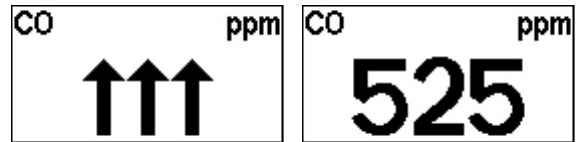

Transmitter with analog current interface 0.2-1 mA:

The current interface outputs a signal in the range 1.0...1.1 mA according to the measured value.

Transmitter with analog current interface 4-20 mA:

The current interface outputs a signal in the range 20...22 mA according to the measured value.

Transmitter with digital Modbus interface (RS-485):

With the Modbus version the display of the transmitter and/or the GMA shows the corresponding measured value alternating with ↑↑↑ (see Indications of special states and malfunctions).

An even more significant exceeding of more than 112 % of the measuring range is indicated in the display by permanent arrows ↑↑↑ and a fast flashing yellow status LED.



Transmitter with analog current interface 0.2-1 mA:

The current interface then outputs 1.1 mA.

Transmitter with analog current interface 4-20 mA:

The current interface then outputs 22 mA.

Transmitter with digital Modbus interface (RS-485):

With the Modbus variant, ↑↑↑ is shown permanently in the displays of the transmitter and/or the GMA (see Indications of special states and malfunctions).

4.2.2 Underrange

Values below the zero point are displayed as a numerical value with a negative sign. If the measured value indicated is between 0 and -5 % of the measuring range, it is still shown on the display of the transmitter or of the controller (e.g. GMA200).

If the measured value indicated is between -5 and -7.5 % arrows ↓↓↓ alternating with the measured value are shown in the display of the transmitter.

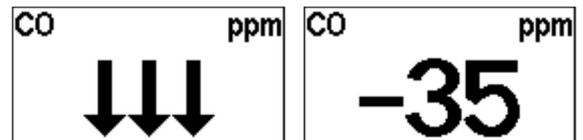

If the measurement signal falls below the value of -7.5 %, the arrows ↓↓↓ are permanently shown on the display.



Transmitter with analog current interface 0.2-1 mA:

The current interface outputs a signal in the range 0.14...0.2 mA according to the measured value.

Transmitter with analog current interface 4-20 mA:

The current interface outputs a signal in the range 2.8...4.0 mA according to the measured value.

Transmitter with digital Modbus interface (RS-485):

With the Modbus variant, the corresponding measured value is shown in the displays of the transmitter and/or the GMA (refer to Displaying Special States).

4.2.3 Push button interface

The push button interface of the transmitter    can be used to make sensor adjustments and settings via the menu.

4.2.4 Display, LED and horn test [TEST]

While in measurement mode, a display and LED test can be triggered on transmitters with a display by briefly pressing the  button.

Thereby all LEDs are activated, all segments of the display are shown and additionally the status LEDs as well as the acoustic signal tone are activated briefly.

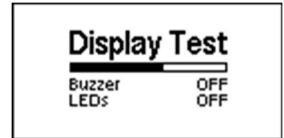

4.2.5 Display of Operating Parameters [INFO]

While measuring is in progress, the following operating parameters can be shown one after the other by briefly pressing the  button.

- Measuring gas
- Measuring unit
- Measuring range
- Concentration of calibration or test gas
- Alarm limits (with alarm function activated)

Gas	Unit	
CO	ppm	
Measurement	Cal. Gas	
500	212	
AL1 ↑	AL2 ↑	AL3 ↑
30	60	150

This information is also displayed during the device startup phase.

4.2.6 Sensor life

Electrochemical sensors have a limited service life. The expected service life of the sensors used in the EC22 is about 1-3 years, depending on the operating conditions. When the expected lifetime is reached, the transmitter indicates that the sensor should be replaced during the next maintenance. A corresponding message is then shown in the red illuminated display and the yellow fault LED lights up briefly every 5 seconds. This has no influence on the measuring operation and the remaining lifetime of the sensor.

4.3 Calibration and Adjustment

4.3.1 Zero point calibration

When calibrating (checking) or adjusting (setting) the zero point, a distinction must be made between oxygen sensors and other electrochemical sensors with regard to the choice of zero gas.

- Oxygen sensors are to be calibrated or adjusted exclusively with 100 vol% N₂.
- For the other electrochemical sensors, fresh air (without interfering gas components) or, in polluted atmospheres, synthetic air can be used.

Calibration (Check):

For this purpose, a calibration adapter is plugged onto the diffusion opening of the transmitter housing. Using the calibration adapter, the zero gas can then be supplied to the sensor without pressure at a flow rate of approx. 0.5 l/min. If the displayed value deviates from zero, the transmitter should be adjusted.

Adjustment of the transmitter:

The adjustment of the zero point can be done in different ways depending on the type of transmitter. These options are described below.

4.3.2 Zero adjustment with display and push button interface [ZERO]

In order to be able to carry out the zero point adjustment, it is necessary to switch to the service code query by pressing and holding the  key (> 3 s). After entering the standard service code "0011" (factory setting), the "ZERO adjustment" program is activated. This is indicated by the flashing of the yellow status LED and, for transmitters with an analog interface (4-20 mA or 0.2-1 mA), by an output signal of 2.4 mA or 0.12 mA.

The display now shows the current measured value (Readout) and the set zero gas concentration. If the measured value is not more than 10 % of the measuring range, the zero point adjustment can be started with the left button [Start]. If the actual measurement value remains constant over a defined time interval, the new zero point is accepted and it is displayed. Use the right key to exit the "ZERO adjustment" program and switch to measurement mode.

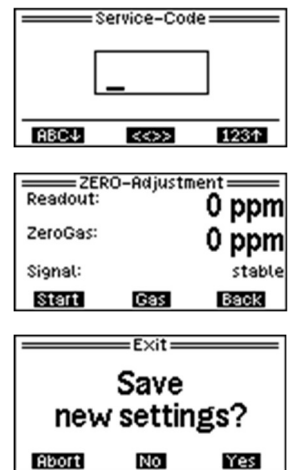

4.3.3 Zero point adjustment with the AutoCal button [ZERO]

For transmitters without a display, the easiest way to perform zero point adjustment is to use the AutoCal button. To operate this button, the transmitter cover has to be removed. To prepare for the adjustment, the button must be pressed for at least 5 seconds. During this 1st phase (0-5 s), the green status LED flashes at 1 Hz and is lit 50 % of the time.

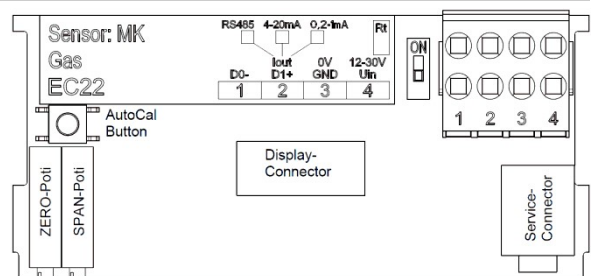

If the button is already released during the 1st phase, i.e. too early, then no adjustment is made and the measuring operation is continued as normal.

After the first 5 seconds, the 1 Hz flashing changes for another 5 seconds such that the green LED is lit only briefly (10 %) each time. In order to start the zero point adjustment, the key must be released during this 2nd phase (5-10 s). The adjustment process is indicated by the flashing of the yellow status LED and a current output signal of 2.0 mA (resp. 0.1 mA). If the measured value remains constant during a defined time interval, the new zero point is accepted and the measured value is set to 0 ppm or 0.0 vol%. A successful adjustment is indicated by fast flashing of the green LED - a failed adjustment, on the other hand, is indicated by fast flashing of the yellow LED. The adjustment process is then automatically terminated.

If the button is pressed for more than 10 seconds, the AutoCal sensitivity adjustment could be started during the 3rd phase (10-15 s), but it would fail because of the missing test gas. If the button is pressed for even longer than 15 seconds, then calibration is also not performed and measurement operation continues as normal.

4.3.4 Zero point adjustment with the ZERO potentiometer

For transmitters without display, zero adjustment can be performed on the ZERO potentiometer using a multimeter with the transmitter lid open. A small screwdriver and a cable with service plug are also required (refer to section 5.5 "Accessories and Spare Parts"). The two connectors at one end of the cable are plugged into the COM input jack and the V input jack, the service connector is plugged into the service connector of the transmitter (refer to Notice).

As long as the ZERO potentiometer is not turned, a voltage value of 0.2-1 V DC can be read on the multimeter, which corresponds proportionally to the current measurement value in the range 0-100 % of the measurement range.

As soon as the ZERO potentiometer is turned, the setpoint for the zero point adjustment can be read on the multimeter. This is indicated by the flashing of the yellow status LED. The setting of the potentiometer must be changed until a voltage value of 0.200 V is displayed. As soon as this setpoint remains unchanged for a longer period of time, the zero point adjustment is started by the transmitter. The yellow status LED turns off as soon as the adjustment process is completed.

Zero adjustment using the ZERO potentiometer can be performed for indicated values up to 25 % of the measuring range. If the transmitter again displays the original (unadjusted) measured value after the adjustment process, despite correct feeding of the calibration gas, the adjustment could not be carried out successfully, probably due to exceeding of the tolerable signal limits or increased signal noise. This can be a indication that the sensor is defective and should therefore be replaced as soon as possible.

Notice:

If no cable with service plug is available, the output current (I_{out}) between terminal 2 and terminal 3 (GND) can alternatively be measured directly for transmitters with analog interface (4-20 mA or 0.2-1 mA). During this process, nothing must be connected to terminal 2 except the multimeter.

4.3.5 Sensitivity calibration



When handling toxic gases special behavioral instructions must be observed depending on the test gas used. Information on this can be found in the corresponding safety data sheets.

For calibration (control) or adjustment of the gas sensitivity, a calibration adapter is plugged onto the diffusion opening of the transmitter housing. Using the calibration adapter, the test or calibration gas (fresh air or synthetic air in the case of an oxygen sensor) is supplied to the sensor without pressure at a volume flow of approx. 0.5 l_{mi}.

The current measured value can be read on the display. If the displayed value deviates from the calibration gas concentration, it is necessary to adjust the sensitivity.

Adjustment of the transmitter:

Before each adjustment of the sensitivity, the zero point should be checked and readjusted if necessary. The adjustment the sensitivity can be done in different ways depending on the typ of transmitter. These options are described below.

4.3.6 SPAN adjustment with display and push button interface [SPAN]

In order to be able to carry out the sensitivity adjustment, it is necessary to switch to the service code query by pressing and holding the  key (> 3 s). After entering the standard service code "0011" (factory setting), the "SPAN adjustment" program is activated. This is indicated by the flashing of the yellow status LED and, for transmitters with an analog interface (4-20 mA or 0.2-1 mA), by an output signal of 2.4 mA or 0.12 mA.

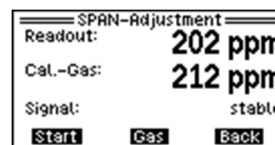
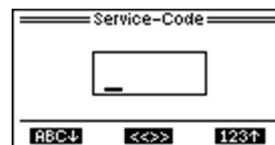

The display now shows the current measured value (Readout) and the set test gas concentration (Cal.-Gas). After pressing the middle button [Gas], the test gas concentration can be modified using the left or right key and saved by pressing the middle key.

If the displayed measured value is at least 7 % of the measuring range, the sensitivity adjustment can be started by pressing the left button [Start]. As soon as a stable measured value is recorded over a defined time interval, the sensitivity is calibrated and the new measured value is displayed. Press the right key to acknowledge the adjustment and exit the "SPAN adjustment" program by switching back to the measuring mode.

4.3.7 Sensitivity adjustment with the AutoCal button [SPAN]

If the test gas concentration set in the transmitter is known and a test gas with this concentration is available, then the easiest way to adjust the sensitivity of transmitters without a display is to use the AutoCal button.

To operate this button, the transmitter cover has to be removed.

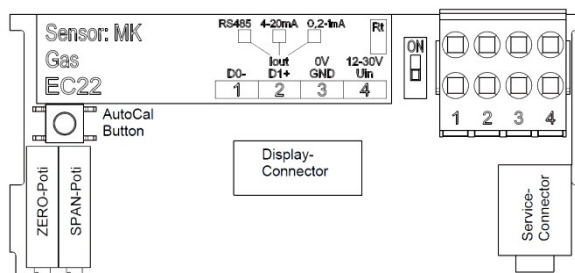

To prepare for the adjustment, the button must be pressed for at least 10 seconds. During a 1st phase (0-5 s), the green status LED flashes at 1 Hz and is lit 50 % of the time. If the button is already released during the 1st phase, i.e. too early, then no adjustment is made and the measuring operation is continued as normal. The 1st phase is followed by a 2nd phase (5-10 s) in which the 1 Hz flashing changes in such a way that the green LED is only lit briefly (10 %). If the button would be released in the 2nd phase, the zero point adjustment would be started.

To start the sensitivity adjustment, however, the button must not be released until the 3rd phase (10-15 s). The 1 Hz flashing of the green LED changes in such a way that the green LED is lit significantly longer (90%). The adjustment process is indicated by the flashing of the yellow status LED and a current output signal of 2.0 mA (resp. 0.1 mA). If the measured value remains constant during a defined period of time, the sensitivity is adjusted in such a way that the measured value indicates the set test gas concentration. A successful adjustment is indicated by fast flashing of the green LED - a failed adjustment, on the other hand, is indicated by fast flashing of the yellow LED. The test gas must now be removed. The adjustment process is then automatically terminated.

If the button is pressed even longer than 15 seconds, then calibration is also not performed and the measuring operation is continued as normal.

4.3.8 Sensitivity adjustment with the SPAN potentiometer

For transmitters without display, sensitivity adjustment can be performed on the SPAN potentiometer using a multimeter with the transmitter lid open. A small screwdriver and a cable with service plug are also required (refer to section 5.5 "Accessories and Spare Parts"). The two connectors at one end of the cable are plugged into the COM input jack and the V input jack, the service connector is plugged into the service connector of the transmitter (refer to Notice).

As long as the SPAN potentiometer is not turned, a voltage value of 0.2-1 V DC can be read on the multimeter, which corresponds proportionally to the current measurement value in the range 0-100 % of the measurement range.

As soon as the SPAN potentiometer is turned, the setpoint for the sensitivity adjustment can be read on the multimeter. This is indicated by the flashing of the yellow status LED. The setting of the potentiometer must be changed until a voltage value of e.g. 0.600 V (for 50 % MR) is displayed. As soon as this setpoint remains unchanged for a longer period of time, the sensitivity adjustment is started by the transmitter. The yellow status LED turns off as soon as the adjustment process is completed.

If the transmitter again displays the original (unadjusted) measured value after the adjustment process, despite correct feeding of the calibration gas, the adjustment could not be carried out successfully, probably due to exceeding of the tolerable signal limits or increased signal noise. This can be a indication that the sensor is defective and should therefore be replaced as soon as possible.

Notice:

If no cable with service plug is available, the output current (I_{out}) between terminal 2 and terminal 3 (GND) can alternatively be measured directly for transmitters with analog interface (4-20 mA or 0.2-1 mA). During this process, nothing must be connected to terminal 2 except the multimeter.

4.3.9 Remote calibration and adjustment

If the EC22 is connected via the RS-485 interface to a GMA which allows for remote calibration (e.g. GMA22-M as of firmware V1.10), then the zero point and gas sensitivity can be adjusted also from the GMA after test gas has been applied to the transmitter. However, before applying the test gas, the test gas concentration (Cal. gas) must be set on the GMA and the calibration mode must be started.

The sequence of feeding zero gas and test gas depends on the gas type and the measuring range.

In the case of transmitters for toxic gases as well as for hydrogen:

With the exception of the oxygen transmitters, which can be adjusted for sensitivity with either fresh air or synthetic air, first the minimum test gas signal must be acquired with zero gas and then the maximum test gas signal with test gas. A complete remote calibration includes the following three phases.



During the first phase, the display of the EC22 shows the text "RemoteCal ... " above the display of the measured value. At the same time, the yellow LED pulses 1x every 5 seconds.

Now the zero gas can be supplied.

The EC22 now attempts to acquire a stable minimum zero gas signal.



During the second phase, the EC22 has acquired a stable minimum zero gas signal. Now the display will show the text "RemoteCal (Z)" above the measured value. The yellow LED then also pulses 2x every 5 seconds with a slight delay.

Now the test gas can be applied.

The EC22 now attempts to acquire a stable maximum test gas signal.

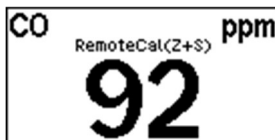

During the third phase, the EC22 detected a stable maximum test gas signal.

Now the display will show the text "RemoteCal (Z+S)" above the measured value. The yellow LED then also pulses 3x every 5 seconds with a slight delay.

Now the test gas can again be removed.

In case of transmitters for oxygen:

For oxygen transmitters whose sensitivity can be calibrated with fresh air or synthetic air, the maximum test gas signal must be acquired first, followed by the minimum test gas signal. A complete remote calibration includes the following three phases.



During the first phase, the display of the EC22 shows the text "RemoteCal ... " above the display of the measured value. At the same time, the yellow LED pulses 1x every 5 seconds.

Now the test gas can be applied.

The EC22 now attempts to acquire a stable maximum test gas signal.



During the second phase, the EC22 has acquired a stable maximum test gas signal. Now the display will show the text "RemoteCal (S)" above the measured value. The yellow LED then also pulses 3x every 5 seconds with a slight delay.

Now Nitrogen as zero gas can be supplied.

The EC22 now attempts to acquire a stable minimum zero gas signal.

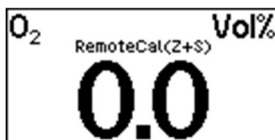

During the third phase, the EC22 detected a stable minimum zero gas signal.

Now the display will show the text "RemoteCal (Z+S)" above the measured value. The yellow LED then also pulses 2x every 5 seconds with a slight delay.

Now the Zero gas can be removed.

The recorded minimum and maximum measured values can now be displayed on the GMA and the zero point and gas sensitivity can be adjusted to the previously set test gas concentrations.

4.4 Main and Service Menu [MENU]

To switch to the main menu and from there to the service menu, the middle button [MENU] must be pressed for at least 3 seconds. Access to the main menu is not protected by an access code.

4.4.1 Main Menu

While the main menu is displayed and also when switching to the various menu items, the transmitter remains in measuring mode. This means that measured value acquisition, processing and signal output continue to function in the background. An exception is the service menu, which is described in the next section. The main menu is divided into:



Main menu with the options:

- Additional Readouts
- Transmitter-Status
- Transmitter-Info
- Service-Menu

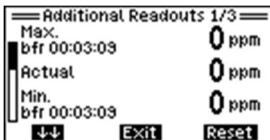

Additional Readouts

Display of further measured values of the transmitter Pressing the left button

() calls up the following values in succession:

- Minimum, maximum and current measured value
Briefly pressing the right key resets the measured value memory.
- Mean values with configured time intervals
Time-weighted averages (in this case of the last 15 minutes, one hour and 8 hours).
- Supply voltage and temperature

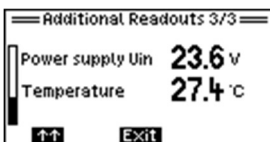
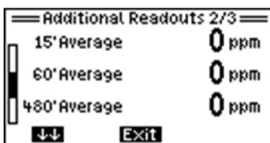

Transmitter-Status



Current system errors, errors in the measuring process, service requirements and events can be called up under the item Transmitter-Status. Behind these categories are numbers in parentheses. These numbers indicate the number of reports available in this category. Exclamation marks signal active events. Available messages can be displayed by selecting the appropriate category and messages regarding no longer active events can be deleted after leaving the detailed display.

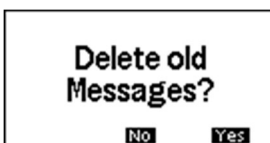
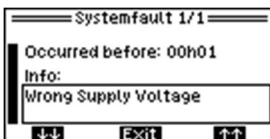

Transmitter-Info



In this device overview, transmitter-specific details such as the firmware version, the device serial number and the sensor type are displayed. If an RS-485 bus interface is available, the configured baud rate and the bus address are also displayed here.

4.4.2 Service-Menu

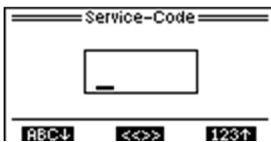

To access the service menu, an access code must be entered. For the standard service menu this is the code "1100". Additional functions are available in an extended service menu. Access to this extended service menu is reserved for GfG service personnel only.

The service menu is organized as follows:



System-Settings This is where you will find general setting options for the RS-485 bus interface or the analog interface, the language, the display contrast, the tolerance band and the horn.

Sensor-Settings: This is where the settings required for the sensor replacement as well as the measuring range selection are located.

Alarm-Settings Alarm limit values can be configured here.

Readout-Simulation This is where measured values can be generated without test gas to check the output signal interface and the downstream signal processing.

The following subsections describe these setting options in more detail.

4.4.2.1 System-Settings



If the transmitter has a RS-485 bus interface, then the **Bus-Address** can be set in between 1 and 247 (0=inactive). A bus address may not be used more than once in the same bus segment.

Bus-Baudrate can be set to 9600, 19200 or 38400 baud. By default it is set to 19200 baud. For very long bus cables the baud rate can be reduced to 9600 baud and for very many bus nodes it can be increased to 38400 baud. Within the same bus segment, the baud rate must be set to the same value for all devices on the bus.

The **Language** can be set to German or English and is relevant for all display outputs especially for the menus.

Display-Contrast can be set between 0 and 100 %. This value may vary from display to display and is usually set to 25...40 %.

Tolerance band can be "ON" or "OFF". When set to "ON" (default), minor signal deviations from zero gas are displayed as 0 ppm or as 0.0 % LEL. The actual measured value is only displayed when the tolerance band is exceeded or undershot. If set to "OFF", the actual measured value is always displayed.

Alarm-Settings activates the alarm function and the associated service menu for alarm configuration.

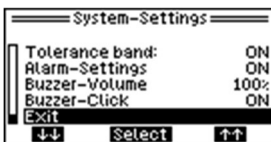

Buzzer volume can be set from 0 to 100 %, but is only relevant if the transmitter is used on site to warn of gas hazards.

Buzzer click can be "ON" or "OFF". If set to "ON" (default), the internal horn generates a short click sound each time a button is pressed.

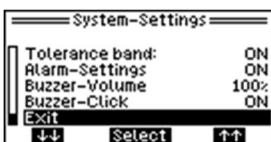

If the transmitter has an analog 4-20 mA (0.2-1 mA) interface, then the current interface itself can be adjusted and tested via the extended service menu at the section **Analog-Interface**.

Iout Adjust: Caution !!! The adjustment of the current interface may only be carried out with the aid of a very accurate current measuring device.

Iout Test: This is where the current output can be tested in the range of 0.5 to 24.5 mA. Caution !!! Connected controllers may respond to these test levels.

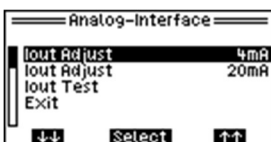

4.4.2.2 Sensor-Settings

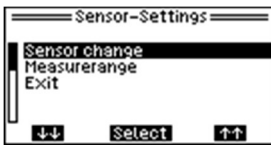

The following sensor-related settings are only possible in the extended service menu:

Sensor change: If the gas sensor is used up and is to be replaced by a new sensor of the same type (MK...), then the serial number of the new gas sensor must be entered under this menu item. After the input is completed, the calibration data of the old sensor is deleted and replaced by default values. The zero point and the gas sensitivity of the new gas sensor must be adjusted in any case.

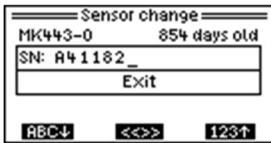

Measuring range: The transmitter is already delivered by GfG with the measuring range requested by the customer. However, if a different measuring range is subsequently required and other measuring ranges are available for the sensor, then a different measuring range can be selected under this menu item.

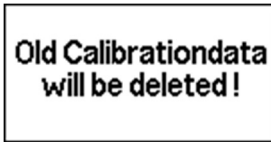

Due to large differences in measuring range and, if necessary, other measuring ranges or gas types, the calibration data of the previous measuring range are not always taken over. If a different measuring range or gas type is selected, the zero point and gas sensitivity may have to be readjusted.

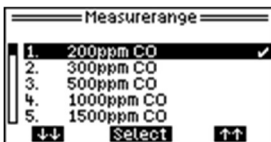

4.4.2.3 Alarm-Settings

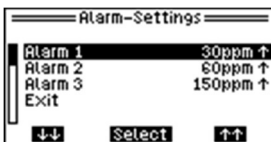

Alarm1 to Alarm3: Selection of the alarm limit value to be configured.



These settings are available for all three alarms:

Limit: Setting of the alarm limit value.

Hysteresis: Activate/deactivate switch-off hysteresis.

Latching: When latching is activated, the alarm remains active until acknowledged.

Direction: Setting whether an alarm is to be triggered when the alarm threshold is exceeded or undercut.

4.4.2.4 Readout-Simulation

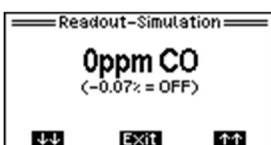

With the help of the readout simulation, the output signal interface, the measured value transmission and the downstream signal processing can be tested. If available, the alarm thresholds can also be checked in this way. This allows measured values to be generated temporarily without the presence of a corresponding test gas.

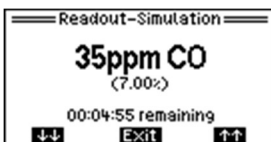

Initially, the display still shows the real, current measured value. The simulation mode is started only after pressing the left or the right button. Above the button labelling, the maximum remaining simulation time is then displayed. If the value of simulated gas concentration is changed using the left or right button, the remaining simulation time will be reset to 5 minutes. If an alarm threshold is exceeded or undershot, an acoustic signal sounds. The simulation mode can be terminated by pressing the middle button. If no button is pressed, the simulation mode will end after the remaining simulation time has elapsed and the system will automatically switch to the measurement mode. An alarm triggered by simulation ends when the menu item is exited.

4.5 Readouts and Messages

4.5.1 Overview of status LED states and current output signals

The following table lists the various display states of the two status LEDs and the current output signals with reference to their meanings.

green LED	yellow LED	Current output	For description see section ...
Off	Flashes with 1 Hz	0.0 mA	Displaying special states ... No. 001
Off	On	0.0 mA	Displaying special states ... No. 002
Off	On	1.2 mA	Displaying special states ... No. 102...111
Flashes once every 5 s	On	1.2 mA	Displaying special states ... No. 101
Flashes with 1 Hz	On	1.6 mA	Displaying special states ... No. 002, 003
On	Flashes with 1 Hz	2.0 mA	Indications in service mode ... No. 204, 205
On	Flashes with 1 Hz	2.4 mA	Indications in service mode ... No. 203
On	Flashes with 1 Hz	4-20 mA	Indications in service mode ... No. 201, 202
On	Flashes once every 5 s	2.8-22 mA	Indications in measuring mode No. 309...316
On	On	2.8 mA	Indications in measuring mode No. 307, 308
On	Off	2.8-22 mA	Indications in measuring mode No. 303...306
On	Flashes with 5 Hz	22 mA	Indications in measuring mode No. 301, 302

4.5.2 Displaying special states (device start and fault)

The following table lists the states when the yellow fault LED is permanently lit and the 4-20 mA current output gives a signal ≤ 1.6 mA.

For the 0.2-1 mA current output, the signals in parentheses apply (≤ 0.08 mA).

Behavior at device startup

No.	Shown in the display	green LED	yellow LED	Current output	Cause	Note/Explanation
001	Boot V1.20 GfG EC22 Error:Flash	Off	Flashes with 1Hz	0.0 mA	During the memory test, an error was detected in the program memory.	Restart transmitter. Firmware update necessary if error message is displayed again.
002	Boot V1.20 GfG EC22 Verify	Off	On	0.0 mA	Program and memory tests during the first seconds of device startup.	After approx. 4 seconds automatic transition to the initialization phase.
003	V2.19 GfG EC22	Flashes with 1Hz	On	1.6 mA (0.08 mA)	Initialization phase of the transmitter.	After approx. 3 seconds automatic transition to sensor warm-up
004	Warm-up XX seconds remaining	Flashes with 1Hz	On	1.6 mA (0.08 mA)	Sensor warm-up	After the time has elapsed, automatic transition to measuring mode

Behavior in case of malfunction:

No.	Shown in the display	green LED	yellow LED	Current output	Cause	Note/Explanation
101	Sensor defective	Flashes once every 5 s	On	1.2 mA (0.06 mA)	Sensor no longer responds correctly to gas. It may be that the sensor is too old.	Sensor must be replaced.
102	Supply voltage incorrect	Off	On	1.2 mA (0.06 mA)	The supply voltage of the transmitter is too low or too high.	Check and readjust the voltage supply.
103	Temp.signal < MIN Temp.signal > MAX	Off	On	1.2 mA (0.06 mA)	Most likely, the temperature measurement is faulty.	
104	Watchdog error	Off	On	1.2 mA (0.06 mA)	A hardware error was detected when testing the external watchdog.	Restart the device. Replace device if error message is displayed again.
105	FLASH Error	Off	On	1.2 mA (0.06 mA)	During the memory test, an error was detected in the program memory.	
106	RAM Error	Off	On	1.2 mA (0.06 mA)	During the memory test, an error was detected in the RAM.	
107	EEPROM error 1 EEPROM error 2 EEPROM error 2c EEPROM error 1+2 EEPROM error 1<>2	Off	On	1.2 mA (0.06 mA)	Error in the parameter memory or when accessing the external parameter memory module.	
108	Wrong PCB type	Off	On	1.2 mA (0.06 mA)	An incorrect PCB type or a PCB error has been detected.	Restart the device. Replace device if error message is displayed again.
109	Digipoti error	Off	On	1.2 mA (0.06 mA)	A hardware error was detected in the digital potentiometer.	
110	ADC error 1 ADC error 2	Off	On	1.2 mA (0.06 mA)	An error was detected at the analog/digital converter.	
111	Program flow error	Off	On	1.2 mA (0.06 mA)	A logical flow error was detected in the program execution.	

4.5.3 Readouts in service mode and during sensor adjustment

The following table lists the states when the green operation LED is permanently lit and the 4-20 mA current output gives a signal between 2.0...2.4 mA.

For the 0.2-1 mA current output, the signals in parentheses apply (0.10...0.12 mA).

No.	Shown in the display	green LED	yellow LED	Current output	Cause	Note/Explanation
201	Adjustment: Zero point (ZERO poti)	On	Flashes with 1Hz	4-20 mA (0.2-1mA)	The AutoCal program for zero point adjustment was activated with the ZERO potentiometer	The zero gas setting is performed by means of the ZERO potentiometer
202	Adjustment: Sensitivity (SPAN poti)	On	Flashes with 1Hz	4-20 mA (0.2-1mA)	The AutoCal program for the sensitivity adjustment was activated with the SPAN potentiometer	The calibration gas setting is made by means of the SPAN potentiometer
203	Menu item	On	Flashes with 1Hz	2.4 mA (0.12 mA)	Service menu was activated via push button interface	Select menu item. If no input is made for one minute, the transmitter automatically returns to the measuring mode
204	Adjustment: Zero point	On	Flashes with 1Hz	2.0 mA (0.10 mA)	Zero point adjustment was activated via push button interface	AutoCal adjustment of the zero point
205	Adjustment: Sensitivity	On	Flashes with 1Hz	2.0 mA (0.10 mA)	Sensitivity adjustment was activated via push button interface	AutoCal adjustment of the sensitivity

4.5.4 Readouts in measuring mode

The following table lists the states when the green operation LED is permanently lit and the 4-20 mA current output gives a signal between 2.8...22 mA.

For the 0.2-1 mA current output, the signals in parentheses apply (0.14...1.1 mA).

No.	Shown in the display	green LED	yellow LED	Current output	Cause	Note/Explanation
301	↑↑↑ permanent	On	Flashes with 5 Hz	22 mA (1.1 mA)	The gas concentration has exceeded the measuring range of the transmitter electronics.	
302	↑↑↑ permanent	On	Flashes with 5 Hz	22 mA (1.1 mA)	The gas concentration has significantly exceeded the measuring range (Gas ≥ 112.5 % MR)	
303	↑↑↑ alternating with measured value	On	Off	20...22 mA (1.0...1.1 mA)	The gas concentration has exceeded the measuring range of (100...112.4 % MR).	
304	Measured value	On	Off	4-20 mA (0.2-1mA)	Trouble-free measurement operation	
305	Measured value	On	Off	3.2...4.0 mA (0.16...0.2 mA)	Underrange (-5.0...0.0 % MR)	
306	Measured value alternating with ↓↓↓	On	Off	2.8...3.2 mA (0.14...0.16 mA)	Underrange (-7.5...-5.0 % MR)	Zero point adjustment is appropriate
307	Permanent ↓↓↓	On	On	2.8 mA (0.14 mA)	Underrange (below -7.5 % MR)	Zero point adjustment is necessary
308	Permanent ↓↓↓	On	On	2.8 mA (0.14 mA)	Measuring signal has fallen below the measuring range of the transmitter electronics	Zero point adjustment is necessary and the sensitivity must be checked
309	<i>Replacing the sensor < 1 month</i>	On	Flashes once every 5 s	2.8...22.0 mA (0.14...1.10 mA)	Expected sensor lifetime soon reached.	Replace or adjust sensor
310	<i>Replace sensor.</i>	On	Flashes once every 5 s	2.8...22.0 mA (0.14...1.10 mA)	Expected sensor lifetime exceeded.	Replace or adjust sensor
Remote calibration (not on transmitters for oxygen)						
311	RemoteCal ... and measured value	On	Flashes once every 5 s		Remote calibration started. A stable minimum zero gas signal is being searched for.	The zero gas can be applied.
312	RemoteCal(Z) and measured value	On	Flashes twice every 5 s		A stable minimum zero gas signal was found for remote adjustment.	The test gas can be applied. The zero point can be adjusted on the GMA.
313	RemoteCal(Z+S) and measured value	On	Flashes three times every 5 s		A Stable maximum and minimum Test gas signal was found for remote adjustment.	Test gas can be removed. Zero point and sensitivity can be adjusted on the GMA.
Remote calibration (only on the transmitter for oxygen)						
314	RemoteCal ... and measured value	On	Flashes once every 5 s		Remote calibration started, a stable maximum test gas signal is sought.	The test gas can be applied.
315	RemoteCal(S) and measured value	On	Flashes three times every 5 s		A stable maximum test gas signal for remote adjustment was found.	Sensitivity adjustment on the GMA is possible. The zero gas can now be applied.
316	RemoteCal(Z+S) and measured value	On	Flashes twice every 5 s		A stable maximum and minimum test gas signal for remote adjustment was found.	Zero gas can be removed. Zero point and sensitivity can be adjusted on the GMA.

4.5.5 Priority of readouts and messages in measuring mode

The readings of states with lower priority are overwritten by the readings with higher priority. The lower priority states are not reset.

Priority	State	For description see section ...	
	significant overrange	Indications in measuring mode	No. 301, 302
	slight overrange	Indications in measuring mode	No. 303
	Underrange	Indications in measuring mode	No. 305...308
	Sensor replacement	Indications in measuring mode	No. 309, 310

Sensor error no. 101 and transmitter error no. 102...113 suspend the measuring operation with their respective messages.

4.6 Fault, cause, remedy

Fault	Cause	Remedy
Zero point can no longer be adjusted	Sensor defective	Replace sensor
Sensitivity can no longer be adjusted	Sensor defective	Replace sensor
Output current has dropped to 0 mA	Fuse or electronics defective	Replace printed circuit board
	Wire interrupted	Reconnect

5 APPENDIX

5.1 Cleaning and Care

External soiling of the transmitter housing can be removed with a cloth moistened by water. Do not use solvents or cleaning agents!

5.2 Service and Maintenance

Service and maintenance includes regular visual inspection, function check and system check as well as repair of the gas detection system. In Germany, "DGUV Information 213-056 (Leaflet T 021 / previously BGI 836 Section 9)" and "DGUV Information 213-057 (Leaflet T 023 / previously BGI 518 Section 9)" apply to this.

5.2.1 Visual inspection

Visual inspection should be performed regularly, with a maximum interval of one month, and should include the following activities:

- Checking the display readings and the status messages, e.g. operating LED "On", alarm and fault LEDs "Off"
- Check for mechanical damage and external soiling

5.2.2 Function check

The function check can be performed at intervals depending on the gas hazard to be monitored. The intervals between checks should not exceed 4 months. In Germany, this maximum inspection interval is specified in regulations T 21 and T 023 of the BG RCI employers' liability insurance association.

It includes the following activities:

- Visual inspection according to section 5.2.1 of these operating instructions
- Checking and evaluating the measured values displayed
- Triggering of the alarm thresholds
- Triggering of test functions for display elements as well as visual and audible alarms without triggering the switching functions
- Checking the stored information on messages, faults and maintenance requests

5.2.3 System check (Proof Test)

The system check must be performed at regular intervals. The period must not exceed 1 year. It includes the following activities:

- Function check according to section 5.2.2 of these operating instructions
- Inspection of all safety functions including the triggering of switching functions.
- Control of parameterization by target/actual comparison
- Control of the reporting and registration functions

5.2.4 Repair

The repair includes all repair and replacement work. They may only be carried out by the manufacturer and by persons authorized by the manufacturer GfG Gesellschaft für Gerätebau mbH. Only original spare parts tested and approved by the manufacturer and original assemblies may be used.

5.3 Replacing the sensor

To replace the sensor the transmitter cover has to be removed. In de-energized state, pull the electronics with the sensor out of the guide rail. After that, the old sensor can be removed and the new sensor can be plugged on. Assembly is carried out in reverse order. Only a sensor of the same type may be used as a replacement sensor, the serial number of which must be entered in the service menu of the transmitter after installation and commissioning.

5.4 Information on the environmentally safe disposal of used parts



According to GfG's general terms and conditions, the customer assumes responsibility for the environmentally safe disposal of the device or any device components (such as replaced sensors). In Germany, this is regulated by §§11, 12 ElektroG. On request, GfG in Dortmund can also handle the proper disposal.

5.5 Accessories and spare parts

	Designation	Item no.
1.	Calibration adapter for transmitters EC22 and IR22	2220200
2.	Calibration adapter for transmitters CC22, ZD22, CS22 and EC22 O	2000209
3.	Test cable with service plug for transmitters EC22, CC22, ZD22, CS22 and IR22	2220201
4.	Replacement sensors for transmitters EC22 and EC22 O	on request

5.6 Sensor specification

MK229-0 Electrochemical sensor for nitrogen monoxide NO

Measuring ranges:	0...10 ppm	0...20 or 30 ppm	0...40 or 50 ppm
Resolution / Tolerance band:	0.05 ppm / ±0.15 ppm	0.1 ppm / ±0.2 ppm	0.1 ppm / ±0.3 ppm
Adjustment time:	t ₅₀ < 5 s	t ₉₀ < 15 s	
Pressure 80 to 120 kPa:	max ±1 ppm or ±7 % of the displayed value		(regarding 100 kPa)
Humidity 15 to 90 % RH:	max ±1 ppm or ±7 % of the displayed value		(regarding 50 % RH @ 20 °C)
Temperature -20 to +40(50) °C:	max ±2(3) ppm or ±7 % of the displayed value		(regarding 20 °C)
Cross sensitivities:	H ₂ S < 35 %; NO ₂ < 5 %; CO = 0 %; SO ₂ = 0 %; (*1)		
Expected lifetime:	3 years in air		
Adjustment time:	3 minutes to 1 day - depending on the switch-off time		

MK390-0 Electrochemical sensor for chlorine Cl₂

Measuring ranges:	0...10/20/50 ppm		
Resolution / Tolerance band:	0.1 ppm / ±0.2 ppm		
Adjustment time:	t ₅₀ < 10 s	t ₉₀ < 30 s	
Pressure 80 to 120 kPa:	max ±0.2 ppm or ±10% of the displayed value		(regarding 100 kPa)
Humidity 10 to 95 % RH:	max ±0.2 ppm or ±10% of the displayed value		(regarding 50 % RH @ 20 °C)
Temperature -20 to +50 °C:	max ±0.2 ppm or ±10% of the displayed value		(regarding 20 °C)
Cross sensitivities:	ClO ₂ : 50 %; F ₂ : 40 %; NO ₂ : 20 %; O ₃ : 20 %; SO ₂ : 18 %; CO ₂ =CO=H ₂ S=H ₂ = 0 % (*1)		
Expected lifetime:	2...3 years in air		

MK390-0 Electrochemical sensor for Fluorine F₂

Measuring ranges:	0...20/50/100 ppm		
Resolution / Tolerance band:	0.1 ppm / ±0.2 ppm		
Adjustment time:	t ₅₀ < 10 s	t ₉₀ < 30 s	
Pressure 80 to 120 kPa:	max ±0.2 ppm or ±10% of the displayed value		(regarding 100 kPa)
Humidity 10 to 95 % RH:	max ±0.2 ppm or ±10% of the displayed value		(regarding 50 % RH @ 20 °C)
Temperature -20 to +50 °C:	max ±0.2 ppm or ±10% of the displayed value		(regarding 20 °C)
Cross sensitivities:	Cl ₂ : 250 %; ClO ₂ : 125 %; NO ₂ : 50 %; O ₃ : 50 %; SO ₂ : 45 %; CO ₂ =CO=H ₂ S=H ₂ = 0 % (*1)		
Expected lifetime:	2...3 years in air		

MK392-0 Electrochemical sensor for hydrogen chloride Cl

Measuring ranges:	0...10/20/30 ppm		
Resolution / Tolerance band:	0.2 ppm / ±0.4 ppm		
Adjustment time:	t ₅₀ < 30 s	t ₉₀ < 90 s	
Pressure 80 to 120 kPa:	max ±1 ppm or ±10 % of the displayed value		(regarding 100 kPa)
Humidity 10 to 95 % RH:	max ±1 ppm or ±10 % of the displayed value		(regarding 50 % RH @ 20 °C)
Temperature -20 to +50 °C:	max ±1 ppm or ±10% of the displayed value		(regarding 20 °C)
Cross sensitivities:	AsH ₃ : 350 %; PH ₃ : 300 %; H ₂ S: 300 %; HBr: 100 %; NO: 45 %; SO ₂ : 40 %; HCN: 35 %; Cl ₂ : 6 %; NO ₂ : 3 %; NH ₃ =CO=CO ₂ =H ₂ = 0 %; (*1)		
Expected lifetime:	2...3 years in air		

MK393-0 Electrochemical sensor for ammonia NH₃

Measuring ranges:	0...100/200 ppm		
Resolution / Tolerance band:	1 ppm / ±3 ppm		
Adjustment time:	t ₉₀ < 60 s (at 20 °C)		
Pressure 80 to 120 kPa:	max 1 ppm or 10 % of the displayed value		(regarding 100 kPa)
Humidity 15 to 90 % RH:	max 1 ppm or 10 % of the displayed value		(regarding 50 % RH @ 20 °C)
Temperature (-20)-10 to +40 °C:	max 1(2) ppm or 15(20) % of the displayed value		(regarding 20 °C)
Cross sensitivities:	H ₂ S ≈ 10 %, CO=CO ₂ =H ₂ = 0 % (*1)		
Expected lifetime:	2...3 years in air		

(*1): Displayed gas concentration with reference to the applied concentration in the range of threshold limit values (TLV).

MK396-0 Electrochemical sensor for hydrogen H₂			
Measuring ranges:	0...1000/2000 ppm		
Resolution / Tolerance band:	2 ppm / ±50 ppm		
Adjustment time:	t ₅₀ < 30 s	t ₉₀ < 90 s	
Pressure	80 to 120 kPa:	max ±10 ppm or ±10 % of the displayed value	(regarding 100 kPa)
Humidity	15 to 90 % RH:	max ±10 ppm or ±10 % of the displayed value	(regarding 50 % RH)
Temperature	-20 to +50 °C:	max ±10 ppm or ±20 % of the displayed value	(regarding 20 °C)
Cross sensitivities:	C ₂ H ₄ ≈ 80 %; NO ≈ 35 %; HCN ≈ 30 %; CO < 20 %; H ₂ S < 20 %; NO ₂ =SO ₂ =Cl ₂ =HCl = 0 %; (*1)		
Expected lifetime:	2...3 years in air		

MK397-0 Electrochemical sensor for ozone O₃(or chlorine Cl₂ or chlorine dioxide ClO₂)			
Measuring ranges:	0...3/5 ppm O ₃	0...5/10 ppm Cl ₂	0...1/3 ppm ClO ₂
Resolution / Tolerance band:	0.01 ppm / ±0.03 ppm	0.02 ppm / ±0.10 ppm	0.01 ppm / ±0.02 ppm
Adjustment time:	t ₉₀ ≤ 150 s		
Pressure	80 to 120 kPa:	max ±0.03 ppm O ₃ or ±10 % of the measuring range	(regarding 100 kPa)
Humidity	15 to 90 % RH:	max ±0.03 ppm O ₃ or ±10 % of the measuring range	(regarding 50 % RH @ 20 °C)
Temperature	-20 to +50 °C:	max ±0.05 ppm or ±15 % of the displayed value	(regarding 20 °C)
Cross sensitivities in the O ₃ MR:	ClO ₂ ≈ 200 %; NO ₂ ≈ 80 %; H ₂ S ≈ -70 %; Cl ₂ ≈ 60 %; SO ₂ ≈ -50 %; CO < 0,1 % (*1)		
Expected lifetime:	2...3 years in air		

MK399-0 Electrochemical sensor for ammonia NH₃	
Measuring ranges:	0...500/1000 ppm
Resolution / Tolerance band:	5 ppm / ±10 ppm
Adjustment time:	t ₉₀ < 90 s (at 20 °C)
Pressure	80 to 120 kPa: max 5 ppm or 10 % of the displayed value (regarding 100 kPa)
Humidity	15 to 90 % RH: max 5 ppm or 10 % of the displayed value (regarding 50 % RH @ 20 °C)
Temperature	-20 to +40 °C: max 5 ppm or 10 % of the displayed value (regarding 20 °C)
Cross sensitivities:	NO ₂ ≈ 65 %; H ₂ S ≈ 60 %; Cl ₂ ≈ 17 %; SO ₂ ≈ -10 %, CO=NO=H ₂ =0 % (*1)
Expected lifetime:	2...3 years in air

MK409-0 Electrochemical sensor for hydrogen cyanide HCN	
Measuring range:	0...20/30/50/100 ppm
Resolution / Tolerance band:	0.1 ppm / ±0.5 ppm
Adjustment time:	t ₅₀ < 25 s t ₉₀ < 60 s
Pressure	80 to 120 kPa: max ±0.5 ppm or ±10 % of the displayed value (regarding 100 kPa)
Humidity	10 to 95 % RH: max ±0.5 ppm or ±10 % of the displayed value (regarding 50 % RH @ 20 °C)
Temperature	-20 to +50 °C: max ±0.5 ppm or ±15 % of the displayed value (regarding 20 °C)
Cross sensitivities:	NO ₂ ≈ -70 %, NO ≈ -5 %, H ₂ S ≈ 0...200 % (depending on filter saturation) CO=CO ₂ =H ₂ =0 % (*1)
Expected lifetime:	2 years in air

MK422-0 Electrochemical partial pressure sensor for oxygen O₂ (for the EC22 O)	
Measuring range:	0.5...25.0(35.0) vol%
Resolution / Tolerance band:	0.1 vol% / ±0.3 vol%
Adjustment time:	t ₉₀ ≤ 5 s
Pressure	70...125 kPa: proportional to the oxygen partial pressure
Humidity	0 to 90 % RH: Negligible
Temperature +10(0) to +40(50) °C:	max ±0.5 vol% or ±3(6) % of the displayed value (regarding 20 °C)
Cross sensitivities:	CO=CO ₂ =H ₂ =H ₂ S=Ar=CH ₄ =C ₃ H ₈ = 0 % (*1)
Expected lifetime:	5 years in air

MK440-0 Electrochemical sensor for sulfur dioxide SO₂	
Measuring ranges:	0...10/20/50/100 ppm
Resolution / Tolerance band:	0.1 ppm / ±0.2 ppm
Adjustment time:	t ₅₀ < 10 s t ₉₀ < 30 s
Pressure	80 to 120 kPa: max ±0.2 ppm or ±5 % of the displayed value (regarding 100 kPa)
Humidity	15 to 90 % RH: max ±0.3 ppm or ±3 % of the displayed value (regarding 50 % RH @ 20 °C)
Temperature	-20 to +50 °C: max ±0.3 ppm or ±5 % of the displayed value (regarding 20 °C)
Cross sensitivities:	C ₂ H ₂ < 300 %; NO ₂ < -170 %; C ₂ H ₄ < 90 %; HCN < 50 %; Cl ₂ < -40 %; NO < 10 %; H ₂ S < 0.4 %; CO < 0.4 %; H ₂ < 0.3 %; NH ₃ = 0 %; (*1)
Expected lifetime:	3 years in air

MK443-0 Electrochemical sensor for carbon monoxide CO	
Measuring ranges:	0...200/300/500/1000/1500/2000 ppm
Resolution / Tolerance band:	1 ppm / ±3 ppm
Adjustment time:	t ₉₀ ≤ 30 s (at 20 °C)
Pressure	80 to 120 kPa: max ±3 ppm or ±5 % of the displayed value (regarding 100 kPa)
Humidity	15 to 90 % RH: max ±3 ppm or ±2 % of the displayed value (regarding 50 % RH @ 20 °C)
Temperature	-20 to +50 °C: max ±3(5) ppm or ±7(10) % of the displayed value (regarding 20 °C)
Cross sensitivities:	C ₂ H ₄ ≈ 96 %; C ₂ H ₂ ≈ 90 %; H ₂ < 30 % (typically 15 %); NO < 20 %; Cl ₂ < 7 %; C ₂ H ₆ O < 0,5 %; SO ₂ =NH ₃ =H ₂ S = 0 % (*1)
Expected lifetime:	3 years in air

(*1): Displayed gas concentration with reference to the applied concentration in the range of threshold limit values (TLV).

MK445-0 Electrochemical sensor for hydrogen sulfide H₂S			
Measuring ranges:	0...30/50/100/200/300/500 ppm		
Resolution / Tolerance band:	0.1 ppm / ±0.3 ppm		
Adjustment time:	t ₉₀ < 30 s		(at 20 °C)
Pressure 80 to 120 kPa:	max ±1 ppm or ±7 % of the displayed value		(regarding 100 kPa)
Humidity 15 to 90 % RH:	max ±1 ppm or ±7 % of the displayed value		(regarding 50 % RH @ 20 °C)
Temperature -20 to +50 °C:	max ±1 ppm or ±7 % of the displayed value		(regarding 20 °C)
Cross sensitivities [#1]:	NO ₂ < 10 %; CO < 2 %; NO < 1 %; CO ₂ =SO ₂ =Cl ₂ =NH ₃ =C ₂ H ₄ = 0 % (*1) low methanol cross-sensitivity		
Expected lifetime:	3 years in air		

MK453-0 Electrochemical sensor for ammonia NH₃			
Measuring ranges:	0...100/200/300/400/500 ppm		
Resolution / Tolerance band:	1 ppm / ±3 ppm		
Adjustment time:	t ₉₀ < 45 s		(at 20 °C)
Pressure 80 to 120 kPa:	max ±1 ppm or ±10 % of the displayed value		(regarding 100 kPa)
Humidity 15 to 90 % RH:	max ±1 ppm or ±10 % of the displayed value		(regarding 50 % RH @ 20 °C)
Temperature (-20)-10 to +50 °C:	max ±1(2) ppm or ±15(20) % of the displayed value		(regarding 20 °C)
Cross sensitivities:	H ₂ S ≈ 120 %; NO ₂ ≈ -100 %; SO ₂ ≈ -30 %; CO=NO=CO ₂ =H ₂ =C ₂ H ₆ O = 0 % (*1)		
Expected lifetime:	2...3 years in air		

MK454-0 Electrochemical sensor for ammonia NH₃			
Measuring ranges:	0...300/500/1000/1500 ppm		
Resolution / Tolerance band:	5 ppm / ±10 ppm		
Adjustment time:	t ₉₀ < 60 s		(at 20 °C)
Pressure 80 to 120 kPa:	max ±5 ppm or ±10 % of the displayed value		(regarding 100 kPa)
Humidity 15 to 90 % RH:	max ±5 ppm or ±10 % of the displayed value		(regarding 50 % RH @ 20 °C)
Temperature -20 to +50 °C:	max ±5ppm or ±10% of the displayed value		(regarding 20 °C)
Cross sensitivities:	H ₂ S ≈ 140 %; NO ₂ ≈ -100 %; SO ₂ ≈ -30 %; CO=NO=CO ₂ =H ₂ =C ₂ H ₆ O = 0 % (*1)		
Expected lifetime:	2...3 years in air		

MK457-0 Electrochemical sensor for nitrogen monoxide NO			
Measuring ranges:	0...50/100/200/300 ppm		
Resolution / Tolerance band:	0.5 ppm / ±2.5 ppm		
Adjustment time:	t ₉₀ < 45 s		(at 20 °C)
Pressure 80 to 120 kPa:	max ±1 ppm or ±10 % of the displayed value		(regarding 100 kPa)
Humidity 15 to 90 % RH:	max ±1 ppm or ±10 % of the displayed value		(regarding 50 % RH @ 20 °C)
Temperature -20 to +50 °C:	max ±2 ppm or ±10 % of the displayed value		(regarding 20 °C)
Cross sensitivities:	H ₂ S < 50 %; NO ₂ < 40 %; C ₂ H ₆ O ±10 %; SO ₂ < 5 %; H ₂ < 1 %; NH ₃ < 1 %; CO < -1 %; CO ₂ =Cl ₂ = 0; (*1)		
Expected lifetime:	3 years in air		

MK458-0 Electrochemical sensor for nitrogen dioxide NO₂			
Measuring ranges:	0...20/30/50/100 ppm		
Resolution / Tolerance band:	0.1 ppm / ±0.5 ppm		
Adjustment time:	t ₉₀ < 30 s		(at 20 °C)
Pressure 80 to 120 kPa:	max ±0.2 ppm or ±10 % of the displayed value		(regarding 100 kPa)
Humidity 15 to 90 % RH:	max ±0.2 ppm or ±10 % of the displayed value		(regarding 50 % RH @ 20 °C)
Temperature -20 to +50 °C:	max ±0.2ppm or ±10% of the displayed value		(regarding 20 °C)
Cross sensitivities:	Cl ₂ ≈ 100 %; H ₂ S < -40 %; NO < 20 %; C ₂ H ₆ O < 1 %; CO < -1 %; SO ₂ < -1 %; H ₂ < -1 %; NH ₃ < -1 %, CO ₂ = 0; (*1)		
Expected lifetime:	3 years in air		

MK465-0 Electrochemical sensor for oxygen O₂			
Measuring range:	0...25/30 vol%		
Resolution / Tolerance band:	0.1 vol% / ±0.3 vol%		
Adjustment time:	t ₂₀ ≤ 5 s t ₉₀ ≤ 15 s		(at 20 °C)
Pressure 80 to 120 kPa:	max ±0.3 vol% or ±2.5 % of the measuring range		(regarding 100 kPa)
Humidity 5 to 95 % RH:	max ±0.3 vol% or ±2.5 % of the measuring range		(regarding 50 % RH @ 40 °C)
Temperature -20 to +50 °C:	max ±0.4 vol% or ±3.0 % of the displayed value		(regarding 20 °C)
Expected lifetime:	3 years in air		

MK466-0 Electrochemical sensor for oxygen O₂			
Measuring range:	0...25/30 vol %		
Resolution / Tolerance band:	0.1 vol % / ±0.3 vol %		
Adjustment time:	t ₂₀ ≤ 5sec t ₉₀ ≤ 15sec		(at 20 °C)
Pressure 80...120kPa:	max. 0.3 vol % or 2.5 % of the measuring range		(regarding 100kPa)
Humidity 15 to 90 % RH:	max. 0.3 vol % or 2.5 % of the measuring range		(regarding 50 % RH @ 40 °C)
Temperature -20 to +50 °C:	max. 0.4 vol % or 3.0 % of the displayed value		(regarding 20 °C)
Expected lifetime:	5 years in air		

(*1): Displayed gas concentration with reference to the applied concentration in the range of threshold limit values (TLV).

MK467-0 Electrochemical sensor for oxygen O₂

Measuring range:	0...25/30 vol %		
Resolution / Tolerance band:	0.1 vol% / ±0.3 vol%		
Adjustment time:	t ₂₀ ≤ 10 s t ₉₀ ≤ 20 s		
Pressure	80 to 120 kPa:	max ±0.2 vol% or ±2.5 % of the measuring range	(regarding 100 kPa)
Humidity	0 to 90 % RH:	max ±0.2 vol% or ±2.5 % of the measuring range	(regarding 50 % RH @ 40 °C)
Temperature	-20 to +50 °C:	max ±0.5 vol% or ±2.5 % of the displayed value	(regarding 20 °C)
Expected lifetime:	2 years in air		

MK477-0 Electrochemical sensor for silane SiH₄

Measuring ranges:	0...10/20/30/40/50 ppm		
Resolution / Tolerance band:	0.1 ppm / ±0.2 ppm		
Adjustment time:	t ₉₀ < 60 s		
Pressure	80 to 120 kPa:	max ±0.1 ppm or ±10 % of the displayed value	(at 20 °C) (regarding 100 kPa)
Humidity	15 to 90 % RH:	max ±0.2 ppm or ±10 % of the displayed value	(regarding 50 % RH @ 20 °C)
Temperature	-20 to +50 °C:	max ±0.3 ppm or ±10 % of the displayed value	(regarding 20 °C)
Cross sensitivities:	H ₂ S ≈ 160 %; PH ₃ ≈ 100 %; SO ₂ ≈ 20 %; H ₂ =CO = 0 %; (*1)		
Expected lifetime:	2...3 years in air		

5.7 Technical Data

Type designation:	EC22
Ambient conditions Operating temperature: Storage temperature: Humidity: Pressure:	-20 to +50 °C (sensor dependent) -25 to +60 °C (recommended 0 to +30 °C) 20 to 95 % RH (sensor dependent) 80 to 120 kPa (sensor dependent)
Power supply Operating voltage: Current consumption without display: with display: with display + horn: Fuses:	24 V DC (12-30 V DC allowed) for RS-485 and 0.2-1 mA version 4-20 mA version typically 10/12/14 mA @ 24/18/12 V max. 32/34/36 mA @ 24/18/12 V typically 16/20/26 mA @ 24/18/12 V max. 38/42/48 mA @ 24/18/12 V max. 25/30/40 mA @ 24/18/12 V max. 47/52/62 mA @ 24/18/12 V 250 mA (not replaceable)
Sensors Measuring range and measuring gas: Sample gas feed:	Sensor dependent Diffusion
Processing of measured values Update time: Readiness Delay:	1 s 5 s plus 20-90 s adjustment time of the sensors
Display & Controls Status LEDs: Display, buttons: AutoCal button: Potentiometer:	green for operation and yellow for fault or service 2.2" graphic display and 3 push buttons (display version) for ZERO and SPAN adjustment (internal) for ZERO and SPAN adjustment (internal)
Service Connector Typ: Analog output: Digital input:	3.5 mm stereo jack socket (internal) 0.2...1.0 V corresponding to 0...100 % MR for sensor calibration for configuration and firmware updates
Signal output analog: or analog: or digital:	4-20 mA (max. load: 650/400/150 Ω @ 24/18/12 V supply) 0.2-1 mA (max. load: 14K1/9K3/4K5 @ 24/18/12 V supply) RS485; half-duplex; 9600/19200/38400 baud; Modbus protocol Slide switch for 120 Ω terminating resistor
Connection cable Cable glands: Connection terminals: Cable (analog): Cable (digital):	1x or 2x M16x1.5 (for cable diameter 4.5-10 mm) 4 double terminals (0.08..2.5 mm ² conductor cross-section) 3-core e.g. LiYY 3x0,34...0,75mm ² or LiYCY 4-core e.g. LiYY 4x0,50...1.5mm ² or bus cable Y(St)Y 2x2x0.8 *1
Housing Protection class: Material: Dimensions: Weight:	IP54 according to IEC 60529 Plastic 96 x 123 x 49 mm (W x H x D) with sensor 125...150g or 170...195g (for version with display)
Approvals/Certifications Electromagnetic compatibility:	DIN EN 50270:2015 Interference emission: Type class I Interference immunity: Type class II

*1: The bus cable Y(St)Y 2x2x0.8 is suitable for the power supply of several bus transmitters via the same cable only for short cable runs. The achievable distance depends on the number and local distribution of transmitters on the bus cable. Refer to section 3.3 for more information.

GfG Gesellschaft für Gerätebau mbH Klönnestraße 99 44143 Dortmund, Germany Phone: +49 231 - 564 00-0 Fax: +49 231 - 564 00-895 Web: GfGsafety.com Email: info@gfg-mbh.com			
Firmware version 2.21	218-000.30_OM_EC22.doc	As of: March 23, 2023	Subject to change

Declaration of Conformity

EU Declaration of Conformity
Transmitter
EC22
EC22 O

Edited: 20.12.2011 Amended: 23.07.2020

GfG Gesellschaft für Gerätebau mbH

Klönnestraße 99
44143 Dortmund
Tel: +49 (231) 56400-0
Fax: +49 (231) 516313
E-Mail: info@gfg-mbh.com
www.gfg.biz



GfG Gesellschaft für Gerätebau mbH develops produces and sells gas sensors and gas warning devices which are subject to a **quality management system** as per DIN EN ISO 9001.

Subject to supervision by means of a **quality system**, surveilled by the notified body, DEKRA Testing and Certification GmbH (0158), is the production of electrical apparatus of instrumentation Group I and II, categories M1, M2, 1G and 2G for gas sensors, gas detectors, gas warning systems in types of protection flameproof enclosures, increased safety, encapsulation and intrinsic safety, as well as their measuring function.

The Transmitters **EC22, EC22 O** comply with council directive **2014/30/EU** for electromagnetic compatibility and with directive **2011/65/EU** (RoHS) on the restriction of the use of certain hazardous substances in electrical and electronic equipment.

The directive 2014/30/EU is complied considering the following standard:

- Electromagnetic compatibility - Electrical apparatus for the detection and measurement of combustible gases, toxic gases or oxygen EN 50270: 2015
- Radio shielding Type class 1
- Interference resistance Type class 2

The EMC test laboratory AMETEK CTS Germany GmbH at Kamen has tested and certified the electromagnetic compatibility.

The directive 2011/65/EU is complied considering the following standard:

- Technical documentation for the assessment of electrical and electronic products with respect to the restriction of hazardous substances EN 50581: 2012

Dortmund, 23 July 2020

.....
B. Siebrecht
QMB

02.6.2018 20:26:04

SIL - Konformitätserklärung EC22

GfG Gesellschaft für Gerätebau mbH

Klönnestraße 99
44143 Dortmund
Tel: +49 (231) 56400-0
Fax: +49 (231) 56400-895
E-Mail: info@gfg-mbh.com
www.gasmessung.de



Erstellt: 12.04.2016

Geändert: 22.07.2020

Einsatzbedingungen

Die SIL-Fähigkeit des Detektors in Verbindung mit den ermittelten Fehlerraten ist nur dann gültig, wenn die folgenden Einsatzbedingungen eingehalten werden:

Die FMEDA zur Ermittlung der Hardwarefehllerraten wurde unter der Annahme erstellt, dass ein zu niedriges Gassignal einen gefährlichen Fehler darstellt. Ein zu hohes Gassignal stellt einen sicheren Fehler dar, da ein Alarm sicher ausgelöst wird, allerdings bei einer niedrigeren Konzentration als notwendig. Aus diesem Grund gelten die Fehlerraten **nicht** für Sauerstoffmangelüberwachung, bei der ein zu hohes Gassignal einen gefährlichen Fehler darstellt.

Der Detektor muss an einer für die Messaufgabe geeigneten Position angebracht, ordnungsgemäß an eine Auswertezentrale angeschlossen, und vom Hersteller GfG Gesellschaft für Gerätebau mbH oder einer autorisierten Vertretung in Betrieb genommen sein.

Transmitter mit analogem Ausgang:

Folgende Statussignale müssen von der verwendeten Auswerteeinheit erkannt werden. Bei Verwendung einer Auswerteeinheit der Firma GfG Gesellschaft für Gerätebau mbH ist das automatisch sichergestellt.

≤ 2,8 mA	Störung (Fault Low) = Transmitterstörung oder Leitungsunterbrechung
> 2,8 bis < 4 mA	Messbereichsunterschreitung — (Messbetrieb)
> 20 bis < 22 mA	Messbereichsüberschreitung — (Messbetrieb)
≥ 22 mA	Störung (Fault High) = Transmitterstörung oder Kurzschluss

Transmitter mit digitalem Ausgang:

Die Sicherheitsfunktion ist ein digitales RS 485 Ausgangssignal mit einem proprietären Protokoll. Statussignale des Detektors einschließlich Störungsmeldungen sind in das digitale Protokoll implementiert. Die funktionale Sicherheit des digitalen Protokolls ist Bestandteil der SIL-Prüfung der zugehörigen GfG-Auswertezentrale z.B. der GMA200.

Die in der Herstellerdokumentation angegebenen Umgebungsbedingungen z.B. bezüglich Temperatur, Feuchte und Druck sind einzuhalten.

Der Detektor muss gemäß Herstellerangaben regelmäßig fachkundig gewartet und mit einem zertifizierten Prüfgas kalibriert werden. Das Kalibrierintervall ergibt sich aus dem Gefahrenpotential der jeweiligen Anwendung. In Deutschland ist dieses Kalibrierintervall in den Regelwerken T 021 der BG-RCI (= DGUV Information 213-056 der Deutschen Gesetzlichen Unfallversicherung) festgelegt.

Jährlicher Proof Test

Mindestens einmal pro Jahr muss ein Proof Test der gesamten Sicherheitskette durchgeführt werden. Für den Transmitter entspricht der Proof Test der Systemkontrolle gemäß Betriebssicherheitsverordnung und umfasst die reguläre Kalibrierung / Justierung ohne zusätzliche Anforderungen.

**SIL - Konformitätserklärung GfG Gesellschaft für Gerätebau mbH
EC22**

Klönnestraße 99
44143 Dortmund
Tel: +49 (231) 56400-0
Fax: +49 (231) 56400-895
E-Mail: info@gfg-mbh.com
www.gasmessung.de



Erstellt: 12.04.2016 Geändert: 22.07.2020

Der Transmitter **EC22** mit analogem 4 - 20mA bzw. mit digitalem RS 485 Ausgangssignal stimmen mit der folgenden Europäischen Norm zur Funktionalen Sicherheit überein:

Funktionale Sicherheit sicherheitsbezogener elektrischer/
elektronischer/programmierbarer elektronischer Systeme **DIN EN 61508-2: 2011**

Es wurden die folgenden Kenngrößen für die Hardware mit Sensor zum einkanaligen und zweikanaligen Einsatz des **Transmitters EC22** mit analogem bzw. digitalem Ausgang bestimmt:

	Einkanaliger Einsatz (1oo1)	Redundanter Einsatz (1oo2)
Sicherheitsfunktion	Detektion toxischer Gase oder Inertisierungsüberwachung	
Sensortyp, Messbereich, Gasart	MK390-0: 0-10ppm / 0-20ppm / 0-50ppm Cl ₂ MK392-0: 0-10ppm / 0-20ppm / 0-30ppm HCl MK393-0: 0-100ppm / 0-200ppm NH ₃ MK409-0: 0-20ppm / 0-30ppm HCN MK440-0: 0-10ppm / 0-20ppm SO ₂ MK445-0: 0-30ppm / 0-50ppm / 0-100ppm H ₂ S MK457-0: 0-50ppm / 0-100ppm / 0-200ppm NO MK458-0: 0-20ppm / 0-30ppm NO ₂	
Gerätetyp	B	
MTTR	72 h	
Proof Test Intervall	1 Jahr	
SFF	84,45% bzw. 84,47%	
SIL-Fähigkeit Hardware	1	2
HFT	0	1
β Faktor	—	10%
λ _{SD} [1/h]	1,12×10 ⁻⁷ bzw. 1,12×10 ⁻⁷	
λ _{SU} [1/h]	3,03×10 ⁻⁶ bzw. 3,02×10 ⁻⁶	
λ _{DD} [1/h]	2,29×10 ⁻⁷ bzw. 2,36×10 ⁻⁷	
PFH = λ _{DU} [1/h]	6,21×10 ⁻⁷ bzw. 6,20×10 ⁻⁷	6,49×10 ⁻⁸ bzw. 6,48×10 ⁻⁸
PFH _{avg} [1/Jahr]	2,78×10 ⁻³ bzw. 2,78×10 ⁻³	2,86×10 ⁻⁴ bzw. 2,86×10 ⁻⁴

Die zugrundeliegende Berechnung der Kenndaten wurde von der Firma GWW GasWarn Dr. Wenker GmbH als unabhängigem Sachverständigen durchgeführt.

Die folgend aufgeführten Einsatzbedingungen und die Sicherheitshinweise in der Betriebsanleitung 218-000.20 sind zu beachten.

Dortmund, den 22. Juli 2020

.....
Dipl.-Kfm. H.J. Hübner
Geschäftsführer

**SIL - Konformitätserklärung GfG Gesellschaft für Gerätebau mbH
EC22**

Klönnestraße 99
44143 Dortmund
Tel: +49 (231) 56400-0
Fax: +49 (231) 56400-895
E-Mail: info@gfg-mbh.com
www.gasmessung.de



Erstellt: 12.04.2016 Geändert: 22.07.2020

Der Transmitter **EC22** mit analogem 4 - 20mA bzw. mit digitalem RS 485 Ausgangssignal stimmen mit der folgenden Europäischen Norm zur Funktionalen Sicherheit überein:

Funktionale Sicherheit sicherheitsbezogener elektrischer/
elektronischer/programmierbarer elektronischer Systeme **DIN EN 61508-2: 2011**

Es wurden die folgenden Kenngrößen für die Hardware mit Sensor zum einkanaligen und zweikanaligen Einsatz des **Transmitters EC22** mit analogem bzw. digitalem Ausgang bestimmt:

	Einkanaliger Einsatz (1oo1)	Redundanter Einsatz (1oo2)
Sicherheitsfunktion	Detektion toxischer Gase oder Inertisierungsüberwachung	
Sensortyp, Messbereich, Gasart	MK397-0: 0-3ppm / 0-5ppm O ₃ MK398-0: 0-25Vol.% O ₂ zur Inertisierungsüberwachung MK399-0: 0-500ppm / 0-1000ppm NH ₃ MK443-0: 0-200ppm / 0-300ppm / 0-500ppm CO MK443-0: 0-1000ppm / 0-1500ppm / 0-2000ppm CO	
Gerätetyp	B	
MTTR	72 h	
Proof Test Intervall	1 Jahr	
SFF	91,01% bzw. 91,04%	
SIL-Fähigkeit Hardware	2	3
HFT	0	1
β Faktor	—	10%
λ _{SD} [1/h]	1,12×10 ⁻⁷ bzw. 1,12×10 ⁻⁷	
λ _{SU} [1/h]	2,45×10 ⁻⁶ bzw. 2,44×10 ⁻⁶	
λ _{DD} [1/h]	2,29×10 ⁻⁷ bzw. 2,36×10 ⁻⁷	
PFH = λ _{DU} [1/h]	2,75×10 ⁻⁷ bzw. 2,74×10 ⁻⁷	2,81×10 ⁻⁸ bzw. 2,80×10 ⁻⁸
PFH _{avg} [1/Jahr]	1,24×10 ⁻³ bzw. 1,24×10 ⁻³	1,26×10 ⁻⁴ bzw. 1,26×10 ⁻⁴

Die zugrundeliegende Berechnung der Kenndaten wurde von der Firma GWW GasWarn Dr. Wenker GmbH als unabhängigem Sachverständigen durchgeführt.

Die folgend aufgeführten Einsatzbedingungen und die Sicherheitshinweise in der Betriebsanleitung 218-000.20 sind zu beachten.

Dortmund, den 22. Juli 2020

.....
Dipl.-Kfm. H.J. Hübner
Geschäftsführer

5.8 Housing drawing and mounting template EC22

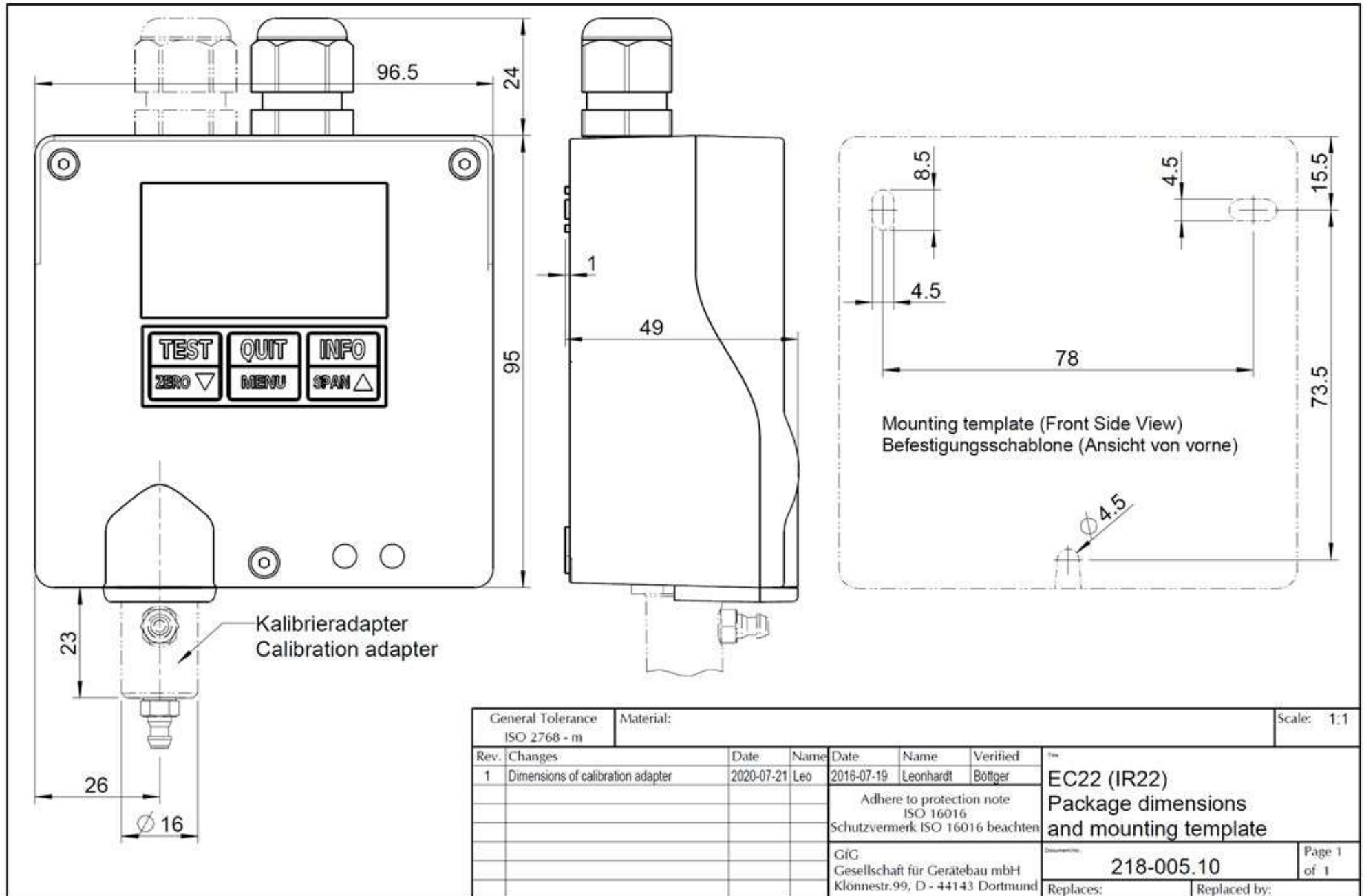

5.9 Housing drawing and mounting template EC22 O

